

# TAYLORMADE CAPACITOR DISCHARGE STUDWELDING SYSTEM



Taylor Studwelding Systems Limited is a specialist in the design, manufacture and supply of Studwelding Equipment and studs. Within our range of British built equipment we will have the system to suit your requirements.

## MICRO PISTOL

Ergonomically designed to provide a fast, safe method of welding in narrow or complicated areas. The Taylor Studwelding Systems Micro Pistol is connected to our standard stud ignition pistol using a standard M6 chuck.

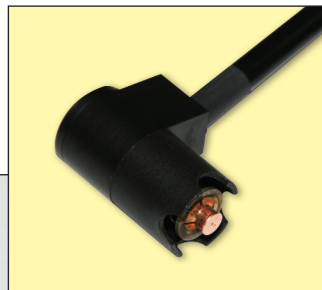
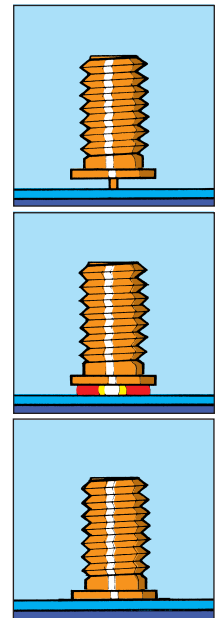

**A TAYLORMADE SOLUTION FOR CAPACITOR DISCHARGE APPLICATIONS WHERE ACCESS IS AN ISSUE**

# TAYLORMADE CAPACITOR DISCHARGE STUDWELDING SYSTEMS

## MINIMUM DISTANCES REQUIRED

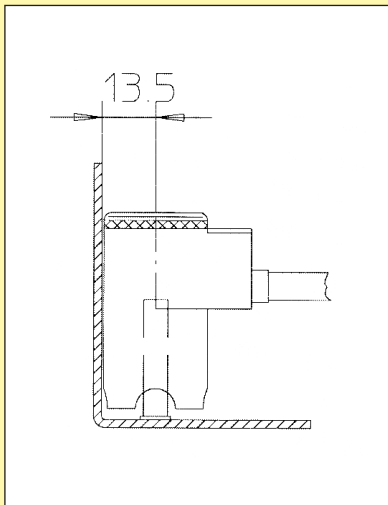

MINIMUM DISTANCE FROM STUD CENTRE TO INSIDE FACE OF VERTICAL WALL IS 13.5mm

SMALLEST OVERHUNG SPACE INTO WHICH WELDING CAN OCCUR IS

$$H = 53\text{MM} + L$$

WHERE L = LENGTH OF STUD

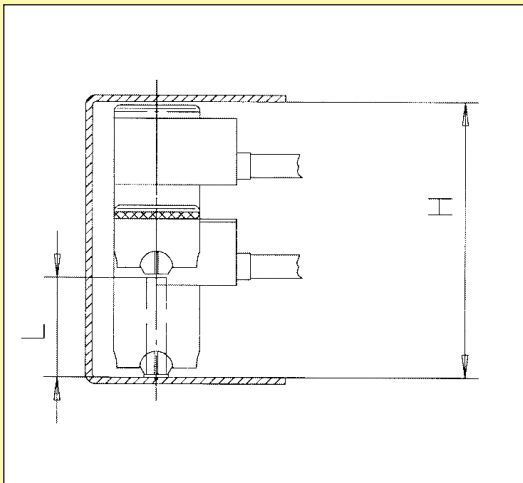

## MICRO PISTOL FEATURES

- Compact
- Lightweight
- Easy to fit
- Easy to use
- Safe

## MICRO PISTOL DATA

Micro Pistol	
Weight (not including cable)	0.2kg
Cable Length	1m
Stud Diameter Range	2.5 - 8mm
Stud Length Range	4 - 30mm
Complete Assembly Order Code	<b>40-17757</b>

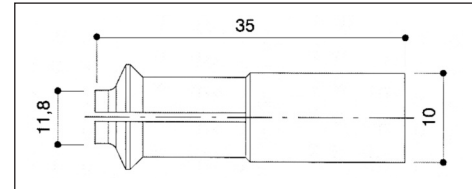

## MICRO PISTOL CHUCKS

Micro Pistol Chucks	
Stud Diameter	Part Number
M3	40-17714
M4	40-17722
M5	40-17730
M6	40-17749
M7.1	40-17854
M8	40-17862



TAYLOR STUDWELDING SYSTEMS LIMITED  
COMMERCIAL ROAD, DEWSBURY, WEST YORKSHIRE, WF13 2BD, ENGLAND  
TEL: +44 (0)1924 452123 FAX: +44 (0)1924 430059  
email: [sales@taylor-studwelding.com](mailto:sales@taylor-studwelding.com) [www.taylor-studwelding.com](http://www.taylor-studwelding.com)